

How is the Vaisala Optimus™ DGA Monitor Different?

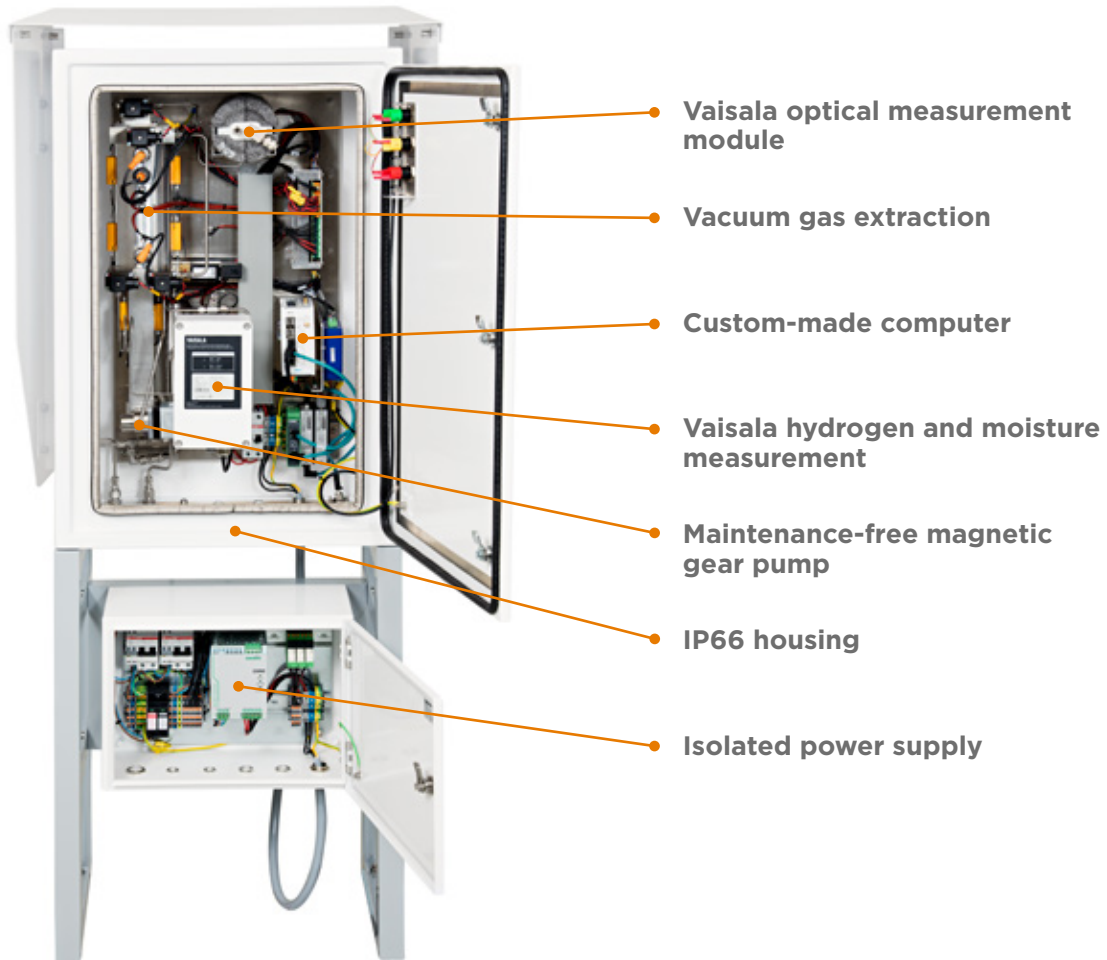

Better Measurement Performance

- Optical IR sensors designed and manufactured in Vaisala cleanrooms
- Spectral scanning provides selective gas measurement
- Vacuum gas extraction independent of oil temperature, pressure, and type
- Unique auto-calibration eliminates long-term drifts – no need to recalibrate

More Robust Design

- Hermetically sealed structure tolerates vacuum and pressure variation
- Stainless steel and aluminum components and piping in contact with oil
- No consumables means no regular maintenance
- Magnetic pump and valves for durability

Simplified Installation and Operation

- Installation and commissioning in as little as two hours
- Continuous operation with one-hour output interval – no data averaging needed
- Browser-based user interface to easily view and share data, and change settings
- Self-diagnostics with self-recovery after disturbances



The Optimus DGA Monitor is the right solution for safe guarding critical transformers in harsh environments

Prevent Power Transformer Failure

There's nothing worse than an unplanned outage, in terms of both lost revenue and the incalculable costs to your reputation and brand. The good news is that over 50 percent of power transformer faults can be detected with the right online monitoring tools, meaning that severe failures can be prevented. But monitors that give false alarms or require regular maintenance can end up wasting considerable amounts of your time and money.

That's why we created the Vaisala Optimus™ DGA Monitor. It provides real-time, trouble free fault gas monitoring for your power transformers – with no false alarms or maintenance.

The two key design drivers have been safety and reliability in demanding operating environments. This is the culmination of decades of listening

to customers' needs and researching existing devices, as well as leveraging our 80 years of experience making sensors and measuring equipment for safety-critical industries and harsh environments.

Dependable Data with No False Alarms

The IR sensor is based on Vaisala core measurement technology and components manufactured in our own cleanroom. Vacuum gas extraction means no data fluctuation due to oil temperature, pressure, or type, while hermetically sealed and protected optics prevent sensor contamination. Moisture is measured directly in the oil with our capacitive thin-film polymer HUMICAP® sensor, which has been used for transformer monitoring for 20 years. Hydrogen is also measured directly in the oil with the same solid-state sensor technology used in the Vaisala MHT410.

Robust Construction

Stainless steel pipes, IP66-rated and temperature-controlled housing, as well as a magnetic pump and valves mean superb performance and durability – from the arctic to the tropics. What's more, there are no consumables to service or replace.

Smart Design

The Vaisala Optimus DGA Monitor has a web-based user interface that completely eliminates the need for additional software. The device is designed to be installed in less than two hours – just connect the oil and power, and it's ready to go. It can be connected to an existing control and monitoring system via digital communication and relays, or used as standalone monitoring device. And in case of a disturbance like a power outage, self-diagnostics allow for self-recovery.

Technical Data

Measured Parameters in Oil

PARAMETER	RANGE	ACCURACY ^{1), 2)}	REPEATABILITY ²⁾
Methane (CH ₄)	0 ... 10000 ppm	10 ppm or 10% of reading	10 ppm or 5% of reading
Ethane (C ₂ H ₆)	0 ... 10000 ppm	10 ppm or 10% of reading	10 ppm or 5% of reading ³⁾
Ethylene (C ₂ H ₄)	0 ... 10000 ppm	10 ppm or 10% of reading	10 ppm or 5% of reading
Acetylene (C ₂ H ₂)	0 ... 5000 ppm	2 ppm or 10% of reading	1 ppm or 10% of reading
Carbon monoxide (CO)	0 ... 10000 ppm	10 ppm or 10% of reading	10 ppm or 5% of reading
Carbon dioxide (CO ₂)	0 ... 10000 ppm	10 ppm or 10% of reading	10 ppm or 5% of reading
Hydrogen (H ₂)	0 ... 5000 ppm	25 ppm or 20% of reading	15 ppm or 10% of reading
Moisture ⁴⁾ (H ₂ O)	0 ... 100 ppm ⁵⁾	± 2 ppm ⁶⁾ or ± 10% of reading	Included in accuracy

¹⁾ Accuracy specified is the accuracy of the sensors during calibration, ²⁾ Whichever is greater, ³⁾ Repeatability of ethane measurement is specified with averaging of five measurements,

⁴⁾ Measured as relative saturation (%RS), ⁵⁾ Upper range limited to saturation, ⁶⁾ Calculated ppm value is based on average solubility of mineral oils

Performance

Measurement cycle length	1 hour (typical)
Response time (T63)	One measurement cycle ¹⁾
Warm-up time to full specification	Three measurement cycles
Data storage	At least 10 years
Expected operating life	>15 years

¹⁾ Three cycles for ethane

Power Supply

Operating voltage	100 ... 240 VAC, 50/60 Hz, ±10%
Overvoltage category	III
Maximum current consumption	10 A
Maximum power consumption	500 W
Typical power consumption at 25 °C (77 °F)	<50 W

Calculated Parameters

Total dissolved combustible gases (TDCG)	Combined total of H ₂ , CO, CH ₄ , C ₂ H ₆ , C ₂ H ₄ , and C ₂ H ₂
Rate of change (ROC)	Available for single gases and TDCG for 24 hour, 7 day and 30 day periods
Gas ratios ¹⁾	Available ratios: CH ₄ /H ₂ , C ₂ H ₂ /C ₂ H ₄ , C ₂ H ₂ /CH ₄ , C ₂ H ₆ /C ₂ H ₂ , C ₂ H ₄ /C ₂ H ₆ , and CO ₂ /CO

¹⁾ Calculated from 24 h average values. See standard IEC 60599

Mechanical

Oil connections at DGA monitor	Swagelok® fitting SS-10M0-61 (2 pcs) for 10 mm (0.393 in) outer diameter pipe. For 3/8 inch pipe, use adapter SS-600-R-10M.
Max length of oil pipe to transformer	Max. 10 m (33 ft) for 6 mm (0.24 in) inner diameter pipe. Max. 5 m (16 ft) for 4 mm (0.154 in) inner diameter pipe
Material	Marine aluminum (EN AW-5754), stainless steel AISI 316

Operating Environment

Oil type	Mineral oil
Required minimum flash point of oil	+110 °C (+230 °F)
Oil pressure at oil inlet	Max. 2 bar _{abs} , continuous Burst pressure 20 bar _{abs}
Oil temperature at oil inlet	Max. +100 °C (+212 °F)
Ambient humidity range	0 ... 100% RH, condensing
Ambient temperature range in operation	-50...+55 °C (-58 ... +131 °F)
Storage and installation temperature range	-40...+60 °C (-40...+140 °F)
Operating altitude	-1000 ... +2000 m (-3280 ... +6562 ft) relative to sea level

Outputs

RS-485 INTERFACE	
Supported protocols	Modbus RTU
Galvanic isolation	2 kV RMS, 1 min
ETHERNET INTERFACE	
Supported protocols	Modbus RTU, TCP, HTTP
Galvanic isolation	4 kV AC, 50Hz, 1 min
RELAY OUTPUTS	
Number of relays	3 pcs, NO or NC user selectable
Trigger type	User selectable: gas level, rate of change, or device status
Max. switching voltage	250 VAC, continuous
Max. switching current	10 A, continuous
USER INTERFACE	
Interface type	Web-based user interface, can be operated with standard web browsers

Power Transformer Monitoring That Works

The Vaisala Optimus™ DGA Monitor delivers out-of-the-box performance, eliminates false alarms, and gives you the best long-term stable measurements for the key fault gases used in transformer diagnostics.

Dimensions

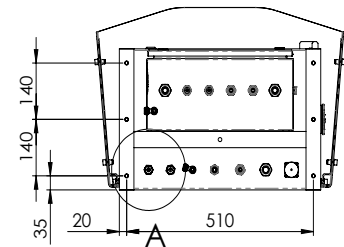
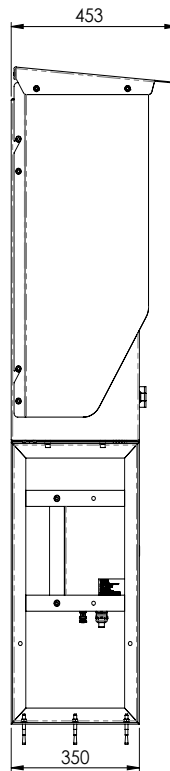
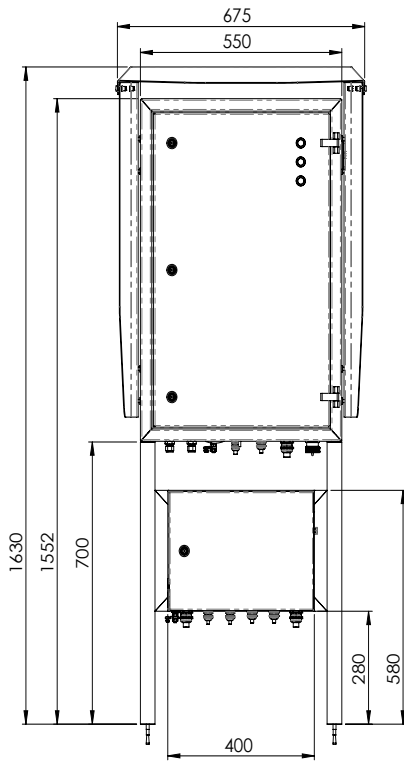

You Can Count on Vaisala

Vaisala has been creating measurement devices for 80 years. Our instruments and systems are used in over 150 countries in industries where failure is not an option, including airports, pharmaceuticals, and power generation. In fact, over 10,000 companies in safety and quality-critical sectors already rely on Vaisala.

Vaisala sensors are so reliable they're used in the harshest places on earth - like arctic, maritime, and tropical environments - and even on Mars.

Safety Information

Tests

CATEGORY	STANDARD	CLASS/LEVEL	TEST
EMC (electromagnetic compatibility)	IEC61000-6-5		Immunity for Power Station and Substation Environments
Environmental	IEC60529	IP66 (equivalent to NEMA 4 rating)	Ingress protection
Safety	IEC/EN61010-1:2010		Product safety

Compliance

CATEGORY	STANDARD
CE marking	EMC directive, Low voltage directive, RoHS directive, WEEE directive

VAISALA

Please contact us at
www.vaisala.com/requestinfo



Scan the code for more information

Ref. B211583EN-A ©Vaisala 2016

This material is subject to copyright protection, with all copyrights retained by Vaisala and its individual partners. All rights reserved. Any logos and/or product names are trademarks of Vaisala or its individual partners. The reproduction, transfer, distribution or storage of information contained in this brochure in any form without the prior written consent of Vaisala is strictly prohibited. All specifications — technical included — are subject to change without notice.

www.vaisala.com